



thermotron  
TEXTILE MACHINERY

**Folding, bagging and stacking** textile machines for  
**increased productivity.**

thermotron **FX25s**  
AUTOMATIC FOLDING MACHINE



thermotron **FX25**  
AUTOMATIC FOLDING MACHINE

- Fold garments quickly, quietly and precisely
- Only 1 operator required
- Fold T-shirts, sweatshirts, sweaters, undershirts, etc.
- Adjustable for the various sizes and types of garments
- Both machines provide a program for easy packaging of the garment in a plastic bag.

adelco  
**SUPPLIED BY**

# thermotron

## Modular Range

All machines are offered and operate as autonomous units or as modules of a full station.

### STP1000

AUTOMATIC FOLDING MACHINE

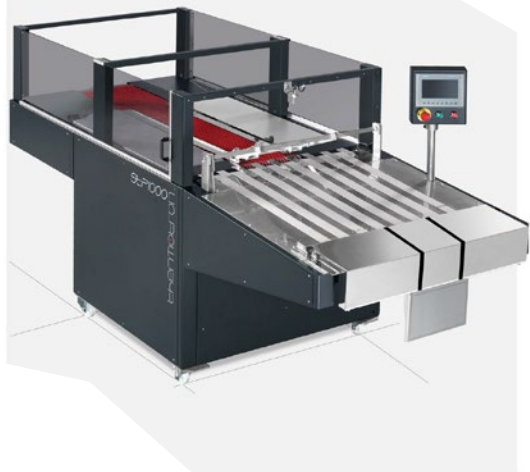

The STP-1000 is the updated version of the successful automatic folding machine STP-950, which was globally marketed in past years. To the new STP-1000, Thermotron have installed state-of-the-art pneumatic, electrical and electronic systems aiming at the even higher quality of its construction and ergonomics.

The automatic folding machine STP-1000 folds ready-made clothes quickly, silently and with precision. It requires just one operator and it is designed to perfectly fold t-shirts. It can be easily adjusted to fold various types and sizes of clothes, within the permissible limits.

A maximum production capacity of 5500 garments per 8 hours.

PV40 is the new automatic bagging machine for garments and constitutes an evolution of its predecessor PV38. With targeted improvements and with a detachable transport belt according to the customer's needs.

The output capacity of PV40 depends on the output speed of STP1000 or on how fast the operator places the garments in the machine when the machine functions independently.

The new automatic PV40, bags garments that come already folded from the automatic folding machine STP1000, into polyethylene (PE) bags in the form of an envelope. If more than one garment needs to be placed in a bag, PV40 can be used independently and the operator can place the garment in the machine manually.

### PV40

AUTOMATIC BAGGING MACHINE



### KL60

AUTOMATIC SEALING MACHINE



The KL-60 is an automatic sealing machine that closes the bags that contain clothes folded and packaged from the automatic folding machine STP-1000, and the bagging machine PV-40.

The machine gives the operator the option to close the bag either with one adhesive tape in its centre or with two tapes at its two ends.

# thermotron

## Modular Range Continued

### BC41

AUTOMATIC LABEL PRINTING AND ATTACHING MACHINE



A new product from Thermotron, a barcode-machine, that prints and attaches labels to plastic bags. When the bags leave the PV40 bagging machine it attaches labels easily and efficiently to plastic bags.

The output capacity of this machine depends on the output speed of the STP1000 folding machine and the speed of the operator.



The NT50 is an automatic stacking machine. The NT50 stacks the already folded garments as they come from the STP1000 automatic folding machine. It can stack folded garments with maximum fold dimensions of width 18 to 32cm, with a maximum stack height of 35cm.

The NT50 is a robust construction that requires very little maintenance and is designed as an alternative to the PV38 bagging machine by Thermotron. The NT50 can stack the garments in bundles, the size of the stack is selected from the touch screen in front of the automatic folding machine STP1000. When the NT50 piled the desired number of garments that are chosen, they are automatically pushed onto the conveyer belt.

### NT50

AUTOMATIC STACKING MACHINE



# Available Combinations

## The Complete Station - Folding, Bagging, Sealing, Labelling



## Folding, Bagging and Sealing



## Folding and Bagging



## Folding and Stacking

